

VACUUM LIFTER

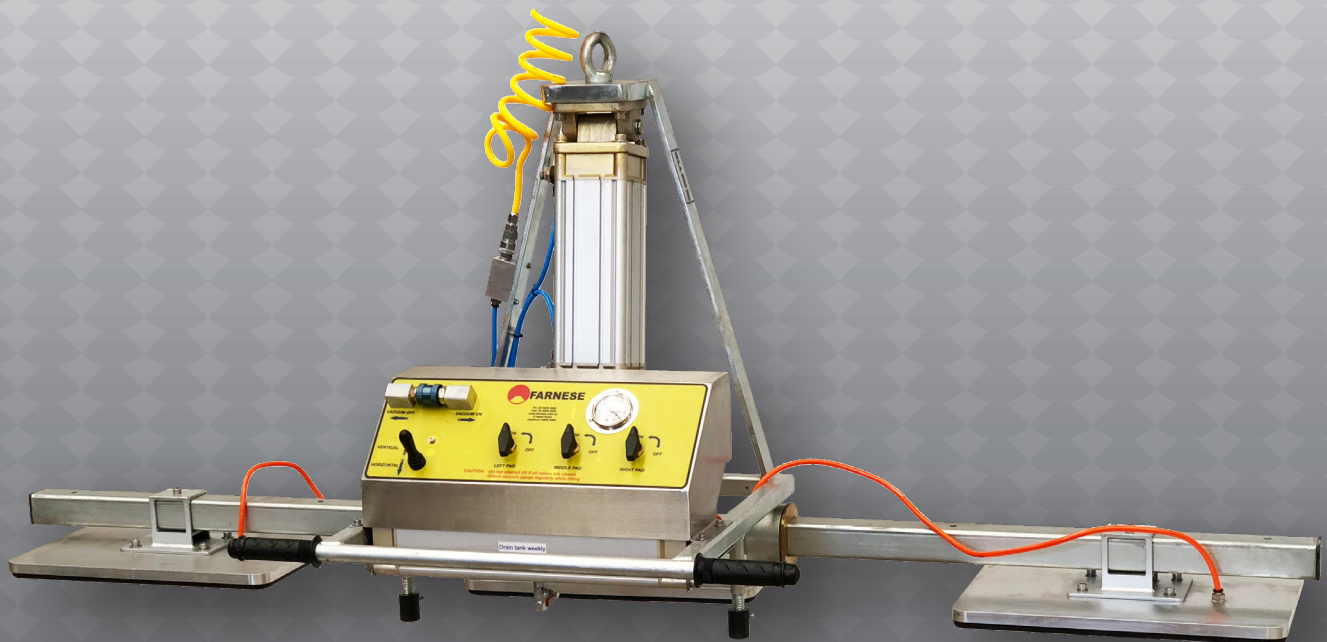

DESIGN FEATURES

500 KG WORKING LOAD LIMIT

3 VACUUM PADS

TILTABLE FROM 0 TO 90°

EASY TO OPERATE

Farnese Australia was founded in 2000 by the Farnese family, whose members have decades of combined professional experience and expertise in both the global stone industry and the local stone machinery manufacturing industry. We are the only designer and manufacturer of stone fabrication machinery in Australia and our machines have found homes throughout Australia, New Zealand, the United States, the United Kingdom, and Vietnam.

With over 20 years of experience in the stone industry, the team at Farnese have the experience it takes to design, install and maintain the equipment needed in your industry.



This essential piece of equipment is fitted with a pneumatic tilting piston which provides complete control of vertical and horizontal positions.

3 individual pads allow you to hold slabs up to 500kg (maximum) and is fitted with a gauge displaying the vacuum intensity.



VACUUM LIFTER

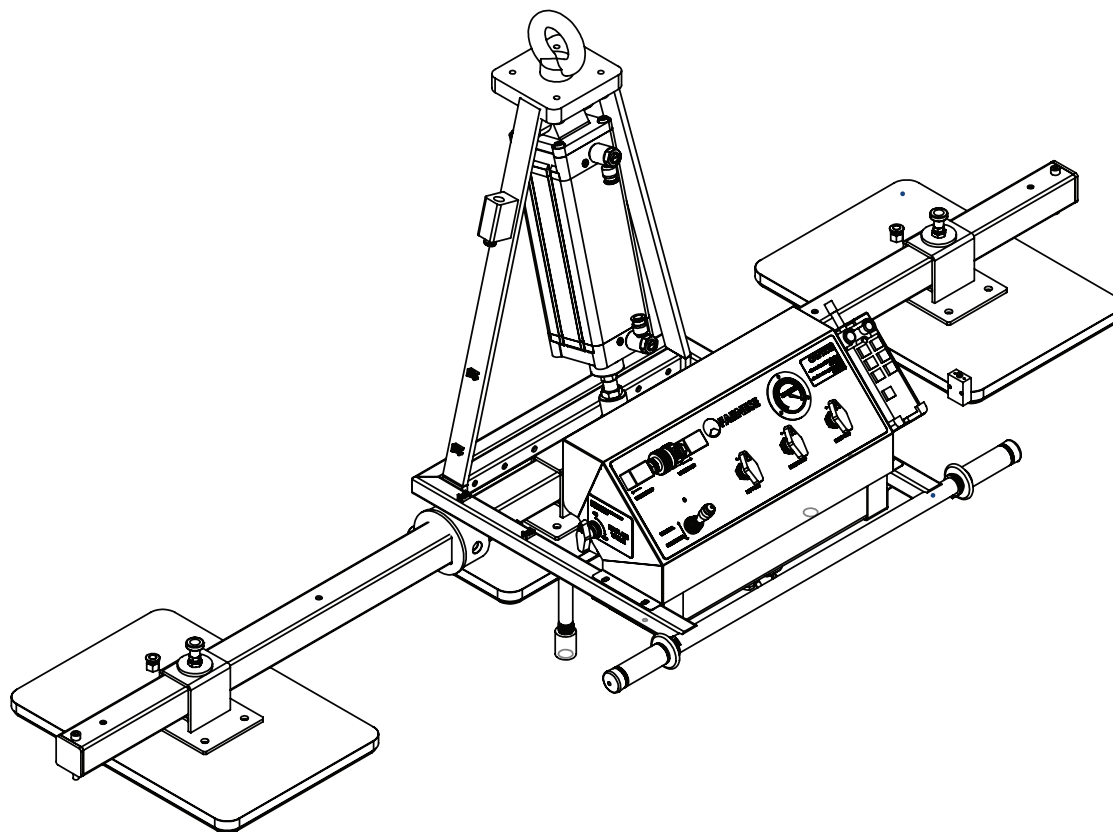

TECHNICAL SPECIFICATIONS

EQUIPMENT DIMENSIONS	METRIC	IMPERIAL
LENGTH	2200 mm	86.6 in
WIDTH	780 mm	30.7 in
HEIGHT	850 mm	33.5 in
WEIGHT	100 kg	220 lb
LOAD (WORKING LOAD LIMIT)	500 kg	1102 lb

EQUIPMENT RANGES	METRIC	IMPERIAL
AIR PRESSURE (WORKING)	7 BAR	102PSI
AIR PRESSURE (CONSUMPTION)	350 l / min	92 gpm
CLEANING VALVE	YES	YES
VACUUM GAUGE	YES	YES
VACUUM GENERATOR	YES	YES
VACUUM PADS	YES / 3 POS	YES / 3 POS
TILTABLE PADS	0 - 90°	0 - 90°

CONNECTIONS REQUIRED (SUPPLIED BY CUSTOMER) -
COMPRESSED AIR

Owing to the constant updating of our designs, descriptions and technical data shown in our drawings and folders are not binding. Possible alterations deemed by the makers as convenient will be effected at any time without previous notice.

5 Heald Road, Ingleburn NSW 2565 Australia
ABN: 47 057 462 629 • ACN: 057 462 629
Phone: 1300 075 678 • www.farnese.com.au

DESIGNED FOR FUNCTION, BUILT TO LAST.

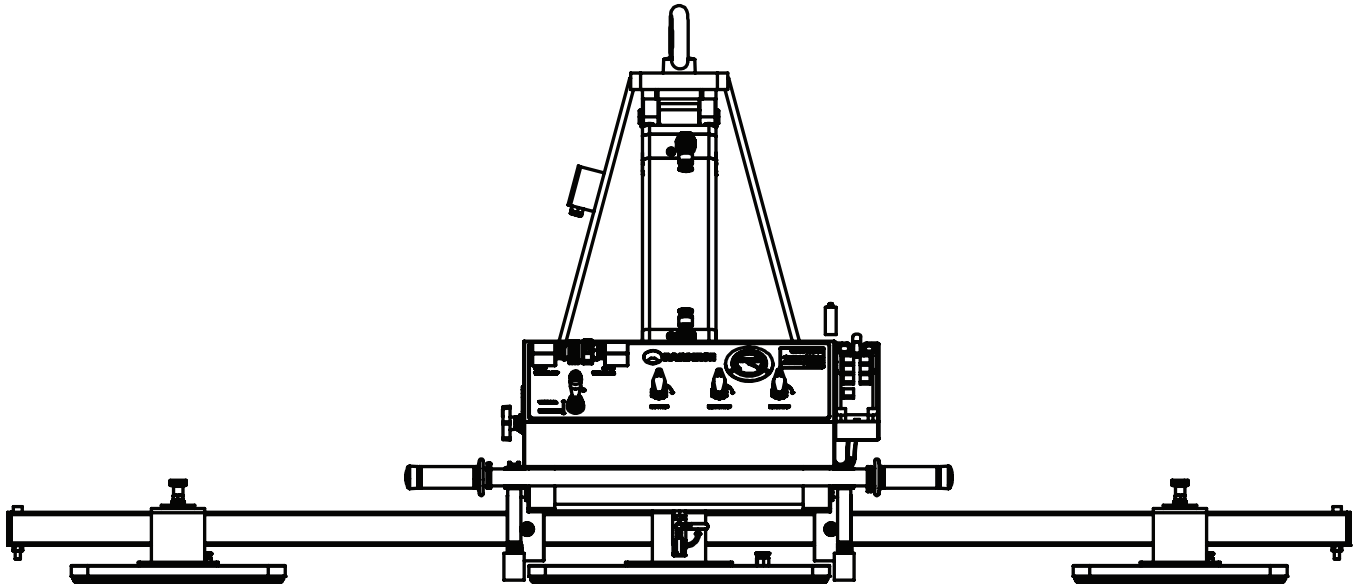

We Know That Support Is Important To You

Buying a new machine is a big commitment for anyone, and continued support throughout the life of that machine is vital.

Being an Australian company, Farnese carry a vast array of parts here in Australia to ensure that your machine always has the spares it needs. Enjoy peace of mind knowing that you'll be fully supported by Farnese and we'll always have you covered.

Farnese customers don't need to experience unnecessary machinery downtime waiting for remote assistance from other countries, as all the support and remote assistance is provided locally in Australia from our own qualified Technicians in Australian time.

With more Service Technicians in Australia than any of our competitors, our mission here at Farnese is to give you the best support in the industry. As we grow, we continue to recruit more and more qualified technicians, to further strengthen our position in the Stone Industry.